



Number: CTSO-C79

Date of approval: Jun 4, 2019

Approved by: Xu Chaoqun

## China Civil Aviation Technical Standard Order

---

This China Civil Aviation Technical Standard Order (CTSO) is issued according to Part 37 of the China Civil Aviation Regulations (CCAR-37). Each CTSO is a criterion which the concerned aeronautical materials, parts or appliances used on civil aircraft must comply with when it is presented for airworthiness certification.

### Fire Detectors (Radiation Sensing Type)

---

#### **1. Purpose.**

This China Civil Aviation Technical Standard Order (CTSO) is for manufacturers applying for Fire Detectors (Radiation Sensing Type) CTSO authorization (CTSOA). This CTSO prescribes the minimum performance standards (MPS) that Fire Detectors (Radiation Sensing Type) must first meet for approval and identification with the applicable CTSO marking.

#### **2. Applicability.**

This CTSO affects new application submitted after its effective date. Major design changes to article approved under this CTSO will require a new authorization in accordance with section 21.353 of CCAR-21R4.

#### **3. Requirements**

New models of Fire Detectors (Radiation Sensing Type) identified

and manufactured on or after the effective date of this CTSO must meet the MPS qualification and documentation requirements in Appendix 1 of this CTSO.

#### **4. Marking.**

Marking should include all the requirement in 21.353(2) of CCAR-21R4 and the operating voltage for the detector shall be shown. Compliance of the detector with the piston or turbine engine requirements, or both, shall be designated by -P, -T, or -PT, respectively, as a suffix following the China civil aviation technical standard order designation as CTSO-C79-P.

#### **5. Application Data Requirements.**

The applicant must furnish the responsible certification personnel with the related data to support design and production approval. The application data include a statement of conformance as specified in section 21.353(a)(1) in CCAR-21R4 and one copy each of the following technical data:

a. A Manual(s) containing the following:

(i) The manufacturer's operating instructions and equipment limitations;

(ii) The installation procedures with applicable schematic drawings, wiring diagrams, and specifications, indicating any limitations,

restrictions, or other conditions pertinent to installation; and

(iii) The manufacturer's test report.

b. The data required under paragraph (a)(i) and (ii) shall include the following:

(i) Cone of vision expressed in degrees (apex of the cone is to be at the center of the sensor and the axis of the cone is to be at right angles to the face of the sensor).

(ii) Maximum effective range at field extremities;

(iii) Maximum allowable normal ambient temperature at the point of detector location;

(iv) Maximum and minimum allowable rate of temperature rise at point of detector location as a result of normal operation;

(v) Operating voltage;

(vi) Mounting or support method;

(vii) Maximum or minimum number of units which can be used in one circuit or one fire zone without adversely affecting sensitivity or causing false indications due to temperature;

(viii) Maximum allowable vibration at point of detector location;

(ix) Installation limitations (minimum distance) because of magnetic effect;

(x) Peak RF voltage and corresponding frequency;

(xi) Whether instrument is for pressurized area, nonpressurized

area or both;

(xii) Which of the conditions in paragraphs 7.3.3, 7.3.4, 7.3.5 and 7.3.6 adversely affect the detector; and

(xiii) Whether detector meets the fire resistance requirements of paragraph 7.14.

---

## **Appendix 1 MPS for Fire Detectors (Radiation Sensing Type)**

### **1.0 Purpose.**

To specify minimum requirements for powerplant fire detection instruments for use in piston and turbine engine-powered aircraft, the operation of which subjects the instrument to environmental conditions specified in paragraph 3.3.

### **2.0 Scope.**

This standard covers the requirements for acceptance of radiation sensing “surveillance” type fire detectors, intended for use in protecting aircraft powerplant installations, auxiliary powerplants, combustion heaters, and other installations where fires may occur. For purposes of this document, the “instrument” shall be considered as the fire warning system and all components thereof.

### **2.1 Definition.**

Radiation sensing type fire detector is an instrument which will initiate an alarm signal when exposed to radiant energy emitted by a flame. The detector and associated circuitry may be designed to be selective with respect to such factors as spectral sensitivity, irradiance level at the detector, rate of rise of irradiance, or frequency characteristics of the fluctuations of irradiance (flicker) or other flame characteristics.

### **3.0 General Requirements.**

#### **3.1 Materials and Workmanship.**

**3.1.1 Materials.** Materials shall be of a quality which experience and/or tests have demonstrated to be suitable and dependable for use in aircraft instruments.

**3.1.2 Workmanship.** Workmanship shall be consistent with high-grade aircraft instrument manufacturing practice.

**3.2 Blank.**

**3.3 Environmental Conditions.** The following conditions have been established as design minimum requirements. Tests shall be conducted as specified in paragraphs 5, 6 and 7.

**3.3.1 Temperature.** When installed in accordance with the manufacturer's recommendations, the instrument shall function over the range of ambient temperatures shown in column A.

<i>Instrument Location</i>	<i>A</i>
Powerplant Compartment (Piston)	-30~+130°C
Power Plant Compartment (Turbine)	-30~+150°C
Pressurized Areas (Both types of engines)	-30~+50°C
Nonpressurized or External Areas (Both types of engines)	-55~+70°C

If the instrument is intended for use in compartments where the maximum ambient temperature is higher than 130° C. for piston engines and 150° C. for turbine engines or if ambient temperatures lower than those specified in column A are anticipated, appropriate special limits shall be selected and specified by the manufacturer.

**3.3.2 Humidity.** The instrument shall function without adverse effect and

shall not be adversely affected when exposed to an atmosphere having any relative humidity in the range from 0 to 95 percent at a temperature of approximately 70° C.

**3.3.3 Altitude.** When installed in accordance with the instrument manufacturer’s instructions, the instrument shall function and shall not be adversely affected by pressure conditions equivalent to those experienced over an altitude range of -1,000 feet to 50,000 feet. Altitude pressures are to be per NACA Report 1235.

**3.3.4 Vibration.** When installed in accordance with the instrument manufacturer’s instructions, the instrument shall function without adverse effect and shall not be adversely affected when subjected to vibrations having the following characteristics:

	<i>Frequency Cycles Per Sec</i>	<i>Max. Double Amplitude in Inches</i>	<i>Maximum Acceleration</i>
<i>Piston Engines</i>			
Airframe Structure Mounted	5~500	0.050	10g
Shock-Mounted Panel	5~50	0.020	1.5g
Powerplant Mounted	5~500	0.100	20g
<i>Turbine Engines</i>			
Nacelle and Nacelle Mounts, Wings, Empenage and Wheel Wells	5~1000	0.036	10g
Fuselage-			
Forward of Spar Area	5~500	0.036	2g
Center of Spar Area	5~1000	0.036	4g

*English Translation Version for Reference Only*

CAAC

CTSO-C79

Aft of Spar Area	5~500	0.036	7g
	500~1000	—	5g
Vibration Isolated	5~50	0.020	1.5g
Racks	50~500	—	0.5g
Instrument Panel	5~500	0.030	1.0g

**3.3.5 Fluids and Sand.** The instrument shall not be adversely affected by exposure to rain, fuel, salt spray, oil, or sand.

**3.4 Radio Interference.** The installation limitations imposed as a result of radio frequency emissions shall be determined and specified.

**3.5 Magnetic Effect.** The installation limitations imposed as the result of a magnetic field shall be determined and specified.

**4.0 Detail Requirements.**

**4.1 Indication Means.** The instrument shall be capable of actuating visual and/or aural alarm indicators.

**4.2 Reliability.** The instrument shall be designed to withstand the mechanical and thermal shocks, and stresses incident to its use in aircraft. False alarm signals shall not result from variations in voltage encountered during operation of the aircraft, abnormal attitudes, contaminants in the atmosphere, ambient light conditions, acceleration forces encountered during flight, landing and takeoff. The fire detector shall not false alarm and the detector sensitivity shall not be appreciably affected by the ambient light in the aircraft compartment in which the sensor is installed, under any combination of normal aircraft operating conditions and atmospheric conditions. Tests aimed at determining the effects of the



foregoing factors on detector reliability are described in paragraph 7.3.

**4.3 Integrity Test Means.** The instrument shall be designed to provide a means for testing the continuity and functioning of the electrical circuits in flight.

**4.4 Calibration Means.** The instrument shall be designed so that all calibration means are provided with tamper-proof seals.

**4.4.1 Adjustable Detector Systems.** Instruments which incorporate an adjustment means shall be tested to prove compliance with this standard, particularly paragraphs 7.1, 7.1.1 and 7.3 throughout the range of adjustability.

## **5.0 Test Conditions.**

**5.1 Atmospheric Conditions.** Unless otherwise specified, all tests required by this standard, shall be conducted at an atmospheric pressure of approximately 29.92 inches of mercury and at an ambient temperature of approximately 25 C. and at a relative humidity of not greater than 85 percent.

**5.2 Vibration.** (To minimize friction): Unless otherwise specified, all tests for performance may be conducted with the instrument subjected to a vibration of 0.002 to 0.005 inch double amplitude at a frequency of 1,500 to 2,000 cycles per minute. The term double amplitude as used herein indicates the total displacement from positive maximum to negative maximum.

**5.3 Vibration Equipment.** Vibration equipment shall be such as to allow vibration to be applied along each of three mutually perpendicular axis of the instrument at frequencies and amplitudes consistent with the requirements of paragraph 3.3.4.

**5.4 Power Conditions.** Unless otherwise specified, all tests shall be conducted at a power rating recommended by the manufacturer, and the instrument shall be in actual operation.

**5.5 Test Position.** Unless otherwise specified, the instrument shall be mounted and tested in its normal operating position.

**6.0 Individual Performance Requirements.** All instruments or components of such shall be subjected to tests by the manufacturer to demonstrate specific compliance with this standard including the following requirements where applicable.

**6.1 Sensitivity and Calibration.** The sensor shall be tested as specified in paragraph 7.1, to determine the response sensitivity and calibration.

**6.2 Dielectric.** Each instrument shall be tested by the methods of inspection listed in paragraphs 6.2.1 and 6.2.2.

**6.2.1 Insulation Resistance.** The insulation resistance between all electrical circuits connected together and the metallic case shall not be less than 5 megohms when 200 volts d.c. is applied for five seconds. Insulation resistance measurements shall not be made to circuits where the potential will appear across elements such as windings, resistors,

capacitors, etc., since this measurement is intended only to determine adequacy of insulation.

**6.2.2 Overpotential Tests.** Equipment shall not be damaged by the application of a test potential between electrical circuits, and the metallic case. The test potential shall be a sinusoidal voltage, of a commercial frequency, with an r.m.s. value of five times the maximum circuit voltage or per paragraphs 6.2.2.1 or 6.2.2.2, whichever applies. The potential shall start from Zero and be increased at a uniform rate to its test value. It shall be maintained at this value for five seconds, and then reduced at a uniform rate to zero.

Since these tests are intended to insure proper electrical isolation of the circuit components in question, these tests shall not be applied to circuits where the potential will appear across elements such as windings, resistors, capacitors, etc.

6.2.2.1 Hermetically sealed instruments shall be tested at 200 volts r.m.s.

6.2.2.2 Circuits that operate at potentials below 15 volts are not to be subjected to overpotential tests.

**7.0 Qualification Performance Requirements.** As many instruments as deemed necessary to demonstrate that all instruments will comply with the requirements of this section shall be tested in accordance with the manufacturer's recommendations. The tests on each instrument shall be conducted consecutively in the order listed, and after the tests have been

initiated, further adjustments to the instrument shall not be permitted. A false alarm signal occurring during any of the tests shall disqualify the instrument. A response time test per paragraph 7.1 shall be conducted after each test, except paragraphs 7.2, 7.2.1, 7.2.3, and 7.14. In conducting the test of paragraph 7.14, the instrument(s) tested need not be the same instrument(s) being subjected to the entire series of qualification tests.

**7.1 Response Time.** The sensor of the instrument shall be exposed, at a distance of four feet to a test flame produced by burning gasoline in a flat pan five inches in diameter and with a flow of air of ten feet per second maximum. The temperature of the gasoline and the pan at the start of each test shall not exceed 85° F. A nonleaded white gasoline shall be used. The response time shall not exceed five seconds.

**7.1.1 Saturation Test.** The sensor shall be mounted facing downward approximately three inches above the center of a flat pan, two feet in diameter, containing gasoline to a level of 1/8-inch from the bottom. The gasoline shall be ignited by a source that cannot be detected by the sensor. The response time shall not exceed five seconds, and the system shall not clear the alarm while exposed to this test for a period of one minute.

**7.1.2 Repeat Response Time.** The sensor of the fire detector shall be exposed to the flame as described in 7.1 for a period of one minute. It shall then be prevented from sensing the flame. Within five seconds after

the alarm has cleared, the sensor shall again be exposed to the flame. An alarm shall be signaled within five seconds.

**7.2 False Alarm Due to Rate of temperature Rise.** The tests described in 7.2.1 and 7.2.2 shall be conducted in a temperature controlled airflow moving at a velocity of 250 feet per minute plus or minus 25 feet per minute. The instrument for this test shall consist of a control unit complete with the maximum number of sensors to be used with a single control unit. No alarm signal shall occur.

**7.2.1 Local Temperature Rise.** One sensor shall be subjected to various combinations of rates of temperature rise and duration of those rates of rise shown in the shaded area of Figure 3(a). The other sensors in the system shall be maintained at ambient room temperature. This test shall be conducted simulating conditions due to local overheating. No alarm signal shall occur.

**7.2.2 General Temperature Rise.** The test described in 7.2.1 shall be repeated using Figure 3 (b) except that all the sensors shall be subjected to the temperature variations simultaneously. The test shall be conducted simulating conditions due to a general temperature rise throughout the compartment where the sensors are located. No alarm signal shall occur.

**7.2.3 False Clearing of Alarm Due to Partial Extinguishment of Fire.** With the instrument arranged to test the response time, in accordance with 7.1, the test flame shall be applied for 30 seconds. The test flame

shall the be masked so as to reduce its effective area by approximately 50 percent. The alarm signal shall not clear. After an additional 30 seconds, the flame shall be removed entirely, and the alarm signal shall clear within 10 seconds.

**7.3 Test Procedures to Establish Detector Reliability Under Special Environmental Conditions.** The following test procedures shall apply to establish detector system reliability under various adverse conditions. In conducting the tests, the system shall contain the critical number of sensors for specific test conditions.

**7.3.1 Blank.**

**7.3.2 Magnesium Flame.** Using the test apparatus and setup given in paragraph 7.1 place a 6 inch length of magnesium ribbon, approximately 1 /8 inch wide and 0.005 inch thick, at a point midway between the sensor element and the fire and in line with the sensor. Ignite the gasoline and while the alarm light is on, ignite the magnesium. The alarm shall not clear while either the magnesium, the gasoline, or both are burning.

**7.3.3 Sunlight.** The test shall be made with sunlight shining directly on the detector (not through a closed window) and the sun shall be within 45° of the zenith so that the slant path through the atmosphere will not be too long. The illumination shall be 5,000 foot-candles or greater, with the light meter probe facing the sun. The detector shall be exposed to sunlight for 30 seconds without actuating the alarm.

**7.3.4 Chopped Sunlight.** In this test, the sunlight (see 7.3.3) shall be modulated by a shutter blade system over a frequency range of 100 cycles per second to 0 cycles per second. This frequency range shall be swept out over a sufficient duration so that there will be a dwell time of a few seconds in any frequency band over the range. A satisfactory chopping arrangement would be a four-bladed shutter on the shaft of a small universal-wound motor operating from a Variac or other source of adjustable voltage. The shutter blades must be large enough to obscure the sun completely from the detector when they are in front of the detector, and blades should be not more than 1 inch away from the detector so that the light from the sky itself will also be modulated. No alarms shall result from the above testing.

**7.3.5 Sunsets and Signal Lights.** An array of colored, incandescent light bulbs shall be used to simulate the calorimetric properties of sunsets at several stages. (This test would also take care of identification and marker lights, and red side of a beacon light, and the anticollision light that flicks past the powerplants). The bulbs shall be 40 watt yellow, orange, and red ones such as General Electric Nos. 40 A/Y, 40 A/O, and 40 A/R, or equivalent. The test is to be conducted in a subdued room illumination of not more than one-foot candle on the detector (too dim to read fine print). The test shall compose an exposure of the detector to each of the three lamps, at 3 feet, for 30 seconds each, without causing an alarm.

**7.3.6 Restricted Light.** The effect of sunlight and incandescent light on the instrument when viewed through apertures of varying sizes shall be determined. The aperture sizes may be chosen arbitrarily but should be representative of openings that might be encountered in an aircraft installation (e.g. vents, scoops, and drains in engine cowling, etc.)

NOTE: If the instrument false alarms during ambient light test requirements of paragraphs 7.3.3, 7.3.4, 7.3.5, and 7.3.6, but otherwise qualifies, installation limitations shall be determined and imposed. These limitations shall be clearly and explicitly stated as part of the required data.

#### **7.4 Vibration.**

Resonance: The instrument, while operating, shall be subjected to a resonant frequency survey of the appropriate range specified in paragraph 3.3.4 in order to determine if there exists any resonant frequencies of the parts. The amplitude used may be any convenient value that does not exceed the maximum double amplitude and the maximum acceleration specified in paragraph 3.3.4.

The instrument shall then be subjected to vibration at the appropriate maximum double amplitude or maximum acceleration specified in paragraph 3.3.4 at the resonant frequency for a period of one hour in each axis.

When more than one resonant frequency is encountered with



vibration applied along any axis, a test period may be accomplished at the most severe resonance or the period may be divided among the resonant frequencies, whichever shall be considered most likely to produce failure. The test period shall not be less than one-half hour at any major resonant mode.

When resonant frequencies are not apparent within the specified frequency range, the instrument shall be vibrated for two hours in accordance with the vibration requirements schedule (paragraph 3.3.4) at the maximum double amplitude and the frequency to provide the maximum acceleration.

Cycling: The instrument, while operating, shall be tested with the frequency varied between limits specified in paragraph 3.3.4 in 15-minute cycles for a period of one hour in each axis at an applied double amplitude specified in paragraph 3.3.4 or an acceleration specified in 3.3.4 whichever is the limiting value.

**7.5 Water Spray.** The instrument components which are to be located outside the pressurized area of the aircraft shall be subjected to the following tests:

**7.5.1 Simulated Rain.** The component shall be subjected to a spray of water to simulate rain for a period of three hours. The component shall not be dried prior to testing, per paragraph 7.1.

**7.5.2 Salt Spray.** The instrument components which are to be installed in

exposed portions of the aircraft shall be subjected to a finely atomized spray of 20 percent sodium chloride solution for 50 hours. At the end of this period, the component shall be allowed to dry and shall be tested per paragraph 7.1.

**7.6 Humidity.** The instrument shall be mounted in a chamber maintained at a temperature of  $70\pm 2$  C. and a relative humidity of  $95\pm 5\%$  for a period of six hours. After this period, the heat shall be shut off and the instrument shall be allowed to cool for a period of 18 hours in this atmosphere in which the humidity rises to 100% as the temperature decreases to not more than 38 C. This complete cycle shall be conducted five times.

Immediately after this cycling, there shall be no evidence of damage or corrosion which affects performance.

**7.7. Fuel and Oil Immersion.** The instrument components which are to be installed in engine compartments or other locations in the aircraft where they may be contaminated by fuel or oil shall be subjected to the following tests:

**7.7.1 Fuel Immersion.** The component shall be immersed in normally leaded grade 100/130 gasoline or turbine engine fuel as appropriate, at room temperature and then allowed to drain for one (1) minute before being tested, per paragraph 7.1. No cleaning shall be accomplished prior to conducting subsequent tests.

**7.7.2 Oil Immersion.** The test procedures out lined in paragraph 7.7.1 shall be conducted with MIL-O-7808 oil (turbine engine oil) or SAE #50 (piston engine oil) as appropriate.

**7.8 Sand.** The instrument components which are to be located in externally exposed portions of the aircraft (such as in nacelles, wheel wells, etc.) shall be subjected to a sand-laden airstream flowing at a constant rate of 2½ pounds of sand per hour for four hours. The airstream shall contain sand that has been sifted through a 150-mesh screen and the particles shall come in contact with all external parts of the component being tested. The test chamber shall be equivalent to that shown in Figure 1.

**7.9 High Temperature Operation.** The instrument shall be subjected to the applicable higher ambient temperature listed in Column A of table in paragraph 3.3.1 Temperature, for a period of 48 hours (electrical equipment energized). Where the highest recommended operating temperature exceeds those of Column A, this higher temperature shall be used. The instrument shall meet, while at that temperature(s), the performance tests described in paragraphs 7.1 and 7.1.1.

**7.10 Low Temperature Operation.** Same as requirement 7.9, except substitute “lower” for “higher”. The instrument shall then meent, at that temperature, the performance tests described in paragraphs 7.1 and 7.1.1.

**7.11 Altitude Effects.**

**7.11.1 High Altitude and Rate of Climb.** The instrument shall be subjected to a pressure that is varied from normal atmospheric pressure to an altitude pressure equivalent to 50,000 feet at a rate of not less than 3,000 feet per minute. The instrument shall be maintained at the altitude pressure equivalent to 50,000 feet for a period of 48 hours. The instrument shall then be tested per paragraphs 7.1 and 7.1.1 under the conditions specified in the first sentence. Sealed components shall not leak as a result of exposure to the pressures stated herein. This shall be demonstrated by immersion of sealed components in water or equivalent and by performing a leak test.

**7.11.2 Low Altitude.** The instrument shall be subjected to the same test as outlined in paragraph 7.11.1, except that the pressure shall be maintained at an altitude pressure equivalent to -1,000 feet and the rate of pressure variation need not be as specified therein.

**7.11.3 Depressurization Test.** The components which are to be located in a pressurized area shall be subjected to a pressure of 22 inches of mercury absolute for a period of 15 minutes. The pressure shall then be reduced to 3 inches of mercury. This reduction in pressure shall be effected in a time period not to exceed 10 seconds. The instrument shall not false alarm while being subjected to this test.

**7.12 Voltage Variation.** The instrument shall be operated with the voltage varied between 75 and 110 percent of the rated voltage. The

instrument shall then be tested per paragraph 7.1 under these conditions. Compliance with the provisions of paragraph 4.2 shall also be demonstrated.

**7.13 Clearance Time.** The instrument shall be exposed to the flame as described in paragraph 7.1 and three determinations made of the time required for the signal to clear. This shall be accomplished by obtaining a response, and immediately turning the instrument so that it ceases to sense (view) the fire, and the time required for the signal to disappear obtained. This time duration is the “clearance time”. It shall not exceed 10 seconds. During this test, the sensor shall be subjected to the most critical vibration (frequency and amplitude conditions as determined in 7.4).

**7.14 Fire Resistance.** For instrument sensing components, including detectors and connecting electrical wire, which are to be installed in a fire zone, tests shall be conducted to show resistance to a completely enveloping flame of 1,100° C. minimum for two periods of one minute each. The flame shall be as specified in Figure 2. The sensor shall be cooled to room temperature after each exposure to flame. The instrument shall then be exposed to the same flame for a third time. An alarm shall be signaled in not more than five seconds after each of the exposures. The instrument shall produce alarm clearance in not more than 45 seconds after the flame has been removed in the first two cases. Artificial means

of cooling the instrument shall not be used until after the alarm has cleared.

If the instrument does not comply with the fire resistance test requirements, but otherwise qualifies, the instrument can be accepted for installation in locations where it would not be subjected to flame. In this case, however, the instrument would be restricted to this type of installation and any other limitations involved.

**7.15 Radio Interference.** Using Stoddard Models M-20B, NM-10A, NM-50A or equivalent noise and field strength meters, measure the RF voltage developed in the various circuitry, tuning the noise meter throughout the range of frequencies from 90 kc. to 1,500 mc. Peak readings in microvolts shall be recorded. When the peak reading is in excess of 200 microvolts, then all readings above 200 microvolts shall be tabulated and installation limits imposed accordingly.

**7.16 Magnetic Effect.** Using a Kueffel and Esser Type 5600 or equivalent magnetic compass, determine the minimum distance between the instrument and compass without causing a compass deflection of more than 5 degrees. In substantiating the minimum distance, compass readings shall be taken in each of the four quadrants of a plane passing through the component's axis.

9/12

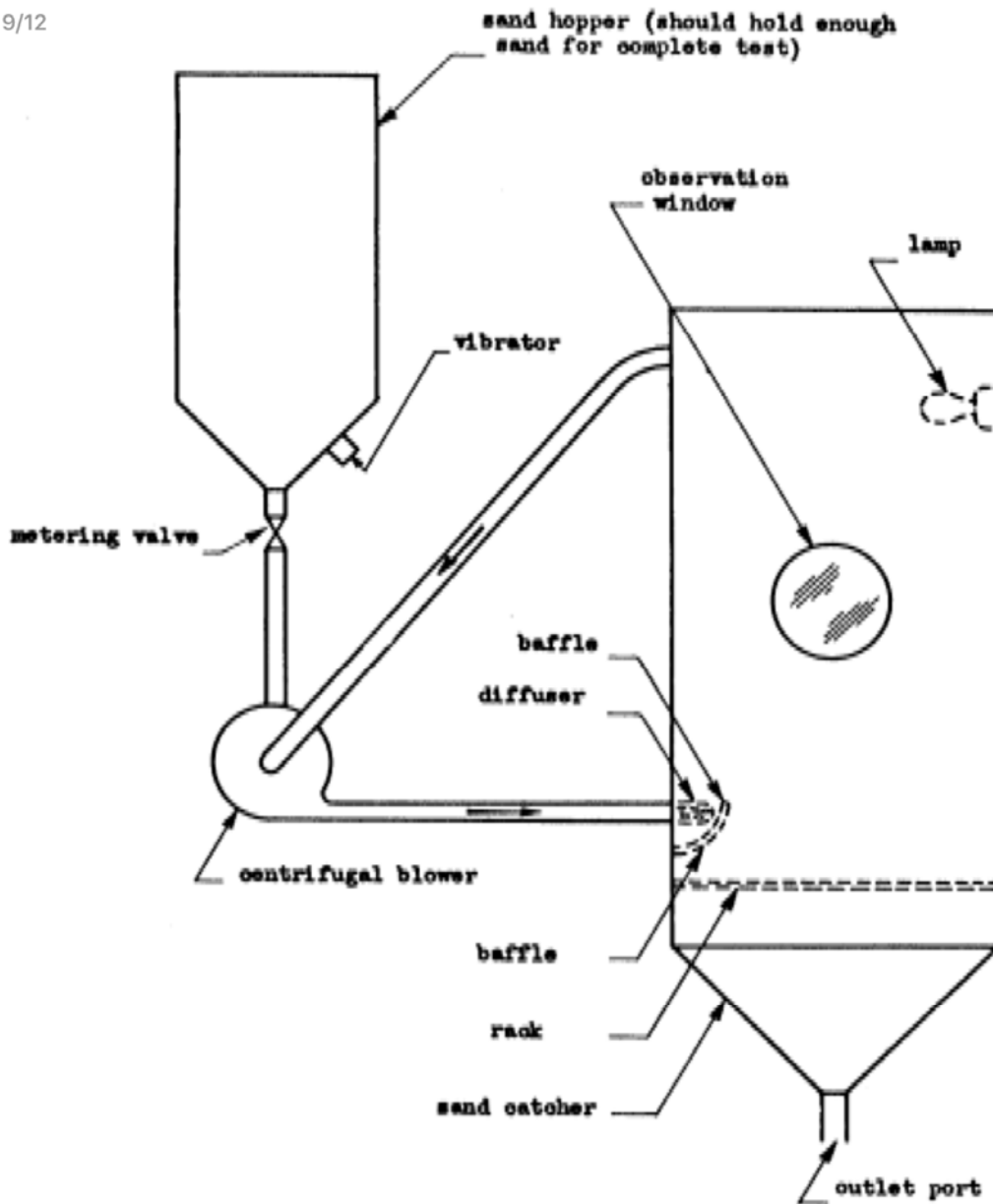

FIGURE 1  
Schematic Sand Test Arrangement (Ref. Section 7.8)

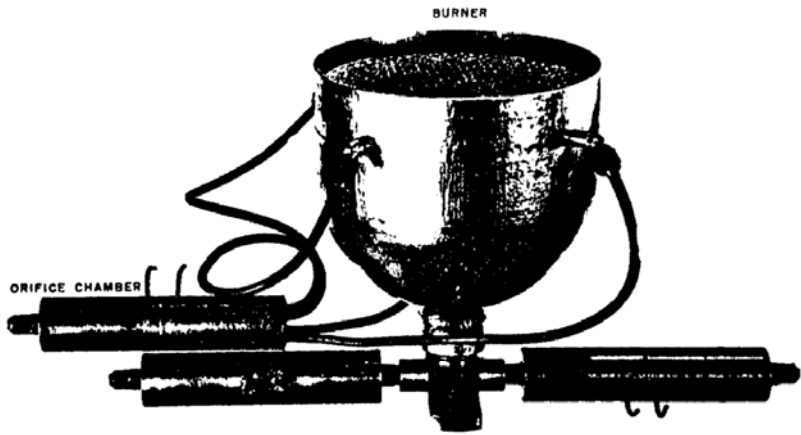

Figure 2-1. Standard Burner Assembly

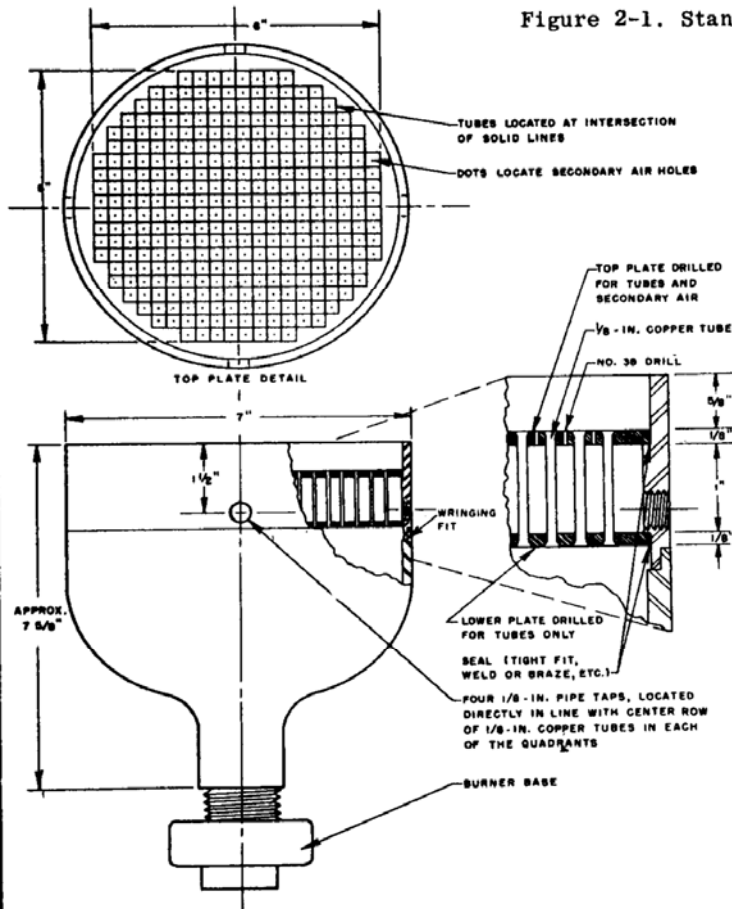

Figure 2-2. Standard Burner



Standard Burner Assembly.

The complete standard burner assembly is shown in Fig. 2-1. Details of the components of this assembly are given in Figs. 2-2, 2-3, and 2-4. Fig. 2-2 shows the details of the burner and the burner grill which consists of two plates connected by 1/8-inch copper tubes. Gas and air are mixed in the burner base and travel upward through the tubes. The burning takes place above the top plate of the burner. Cooling air is admitted to the burner through the four 1/8-inch pipe-tapped holes between the plates of the burner

grill. This air passes upward through the No. 38 drill holes in the top plate and serves as a means for controlling the overall temperature of the flame. The location of the four 1/8-inch pipe-tapped holes is critical. They must be located directly in line with the center row of 1/8-inch copper tubes in each of the four quadrants. Improper location of these connections will result in an unequal radial distribution of cooling air and will affect the distribution of the flame temperature in a like manner.

Fig. 2-3 shows the details of the burner base. When the two 11/32-inch-diameter holes in the burner plug are drilled, care should be taken that the center line connecting these holes will be at right angles to the center line connecting the two 19/64-inch diameter holes in the base. When these 11/32-inch diameter holes are properly located, the 19/64-inch diameter holes cannot be seen when one looks vertically downward into the burner base. This misalignment of holes aids in the mixing of the gas and air before they ascend to the burner grill.

Fig. 2-4 shows the details of an orifice and of an orifice chamber. Three are required. Two of these orifice chambers have end plates with the 3/8-inch Parker thread fittings on both ends and are fastened directly into the burner base. The third orifice chamber has an end plate with a Parker thread fitting on one end and the plate with four 1/4-inch-diameter holes in the other end. This end of the chamber is connected to the burner by four copper tubes, each 1/4 inch in outside diameter (OD) and 13 1/2 inches long. One of the orifice chambers connected to the base is for measuring the gas supplied to the burner and has an orifice 5/32 (0.01625) inch in diameter. The other orifice chamber connected to the base is for measuring the mixing air supplied to the burner and has an orifice 1/4 (0.25) inch in diameter. The third orifice chamber connected to the burner by four 1/4-inch OD copper tubes is for measuring cooling air supplied to the burner and has an orifice 5/16 (0.3125) inch in diameter.

The gas should deliver approximately 2500 British thermal units (BTU) per cubic foot. The burner should consume 26 cubic feet of gas per hour for the 2000°F (1100°C) flame. The flame produced should be uniform and steady with no yellow tips.

The differential manometer readings of the pressure drops across the orifice should be:

1. Gas orifice (5/32-inch diameter), 0.99 inch of water.
2. Mixing-air orifice (1/4-inch diameter), 9.25 inches of water.
3. Cooling-air orifice (5/16-inch diameter), 11.0 inches of water.

In order that the burner might produce the right amount of heat, the differential pressure for the gas and the mixing air should be accurately controlled. A slight variation in the cooling air may be necessary in order to obtain the proper temperature.

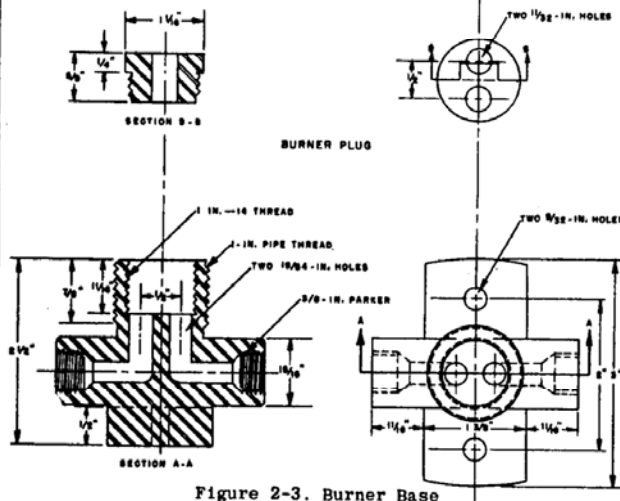

Figure 2-3. Burner Base

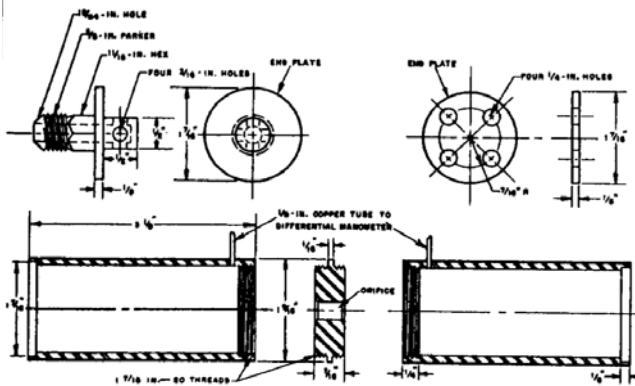
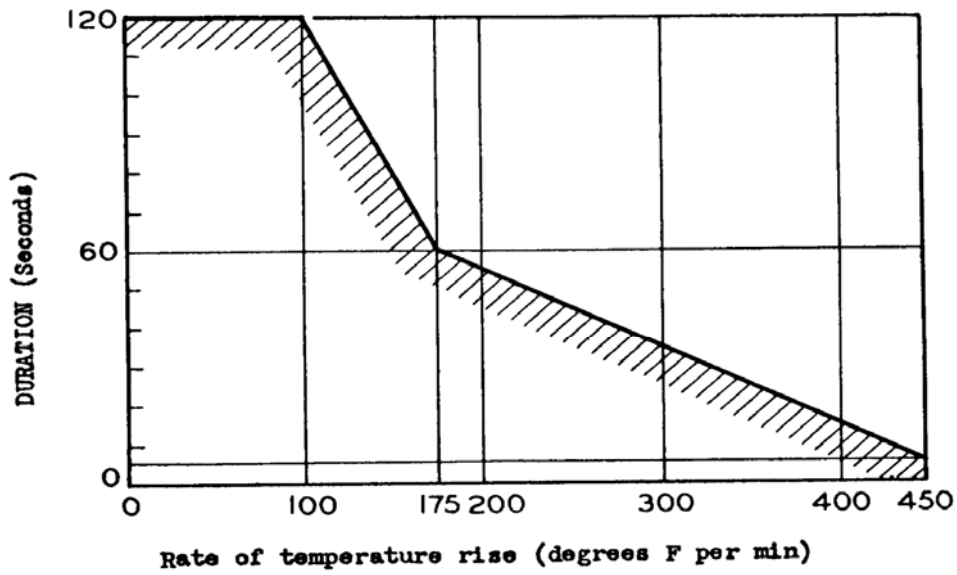
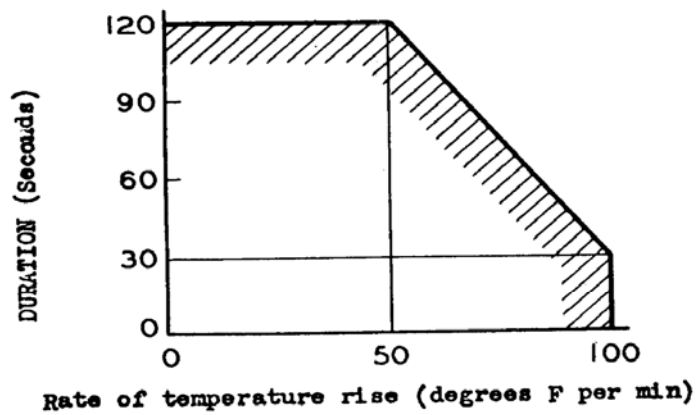

Figure 2-4. Orifice Chamber



**FIGURE 3 (a)**

Local temperature rise condition  
(Ref. Section 7.2.1)



**FIGURE 3 (b)**

General temperature rise condition  
(Ref. Section 7.2.2)